

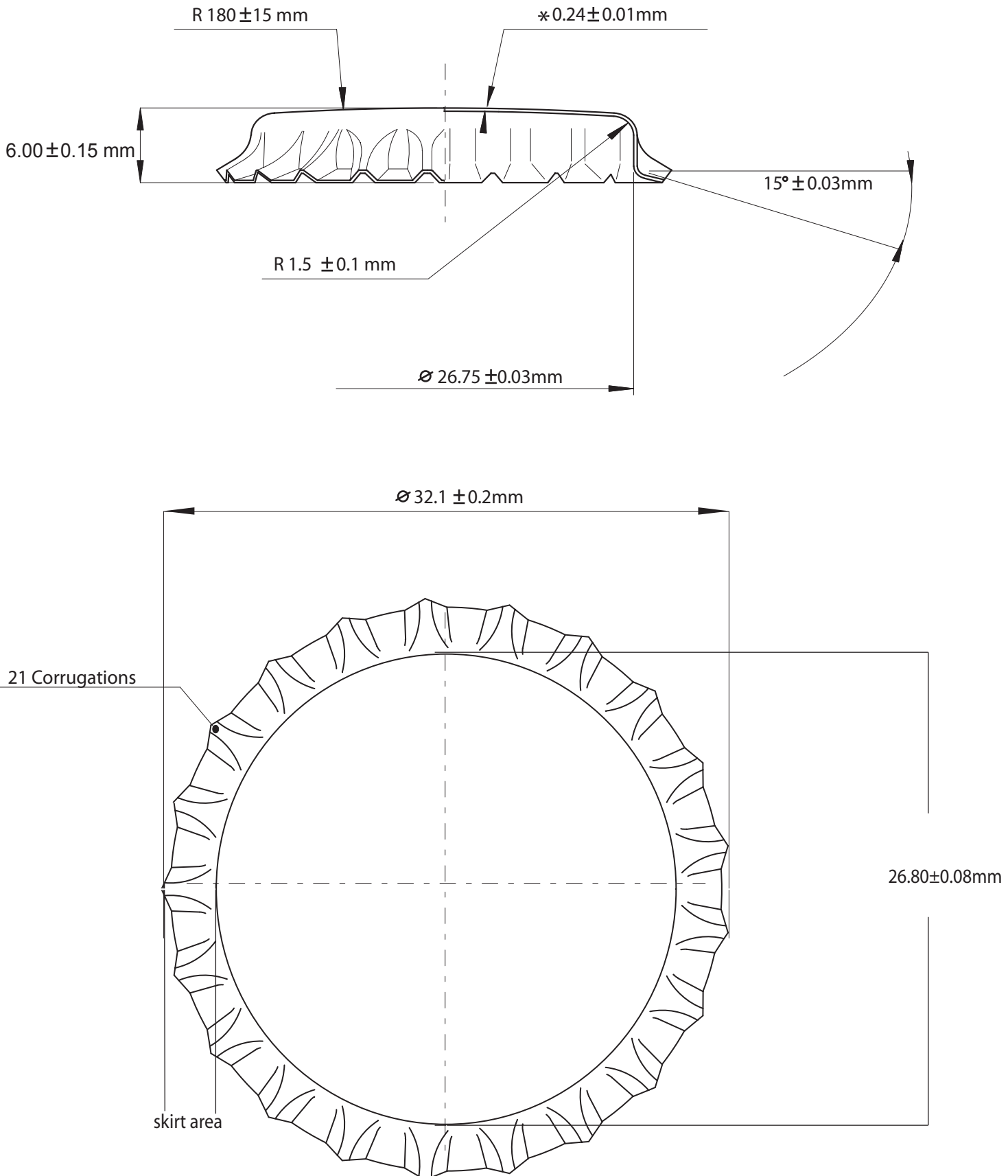

Document title : crown cork specifications



Remaks : Shown dimension before use

- Above specifications include acceptable tolerances for the crown cork application. Astir possesses all exclusive property, trademark and any other rights concerning all dimensional specifications. We do not undertake any liability regarding the observance of copyrights, trademarks or any other rights of third parties, even though has been supplied by ourselves.



Document title : Techical data sheet

Product Description	: Intermediate size crown corks of 6.00mm height
Application	: Crown corks are designed to secure seal in capping applications with glass and aluminum bottles in the brewing and beverage market.
Characteristics	
Steel	: Tin Free Steel (TFS) or Electrolytic TinPlate (ETP)
Finish	: Bright / stone / matt
Specifications	: 0,22mm ±0.01mm T4CA, : 0,20mm ±0.01mm T5CA, : EN 10 202/01, as per JIS G3315, JIS G3303, MR Type
Liner	: Dry blend PVC Free, PVC, Oxygen Barrier, Twist Off
Color	: White, Transparent and Opaque
Profile formulation	: 916, 923 and 917
Weight	: 175 ± 15 mgr (PVC Free) or 220 ± 20 mgr (PVC)
Information	
Odor	: Odor free
Sealing	: min 90 PSI , up to 150 PSI
Opening torque	: from 4 to 9 lb / in.
Shelflife	: Best use within 12 months
Storage	: In clean and dry area, away from direct sunlight and at temperatures not exceeding more than 40°C.
Conformity	: With all European Framework Regulation EC/1935/2004 on food-contact materials and requirements set out in USFDA 21 CFR 177.1210 - Closures with sealing gaskets for food containers.
Packaging	
Carton boxes	: In strong carton boxes of 10.000pcs with inner polyethylene bag for protection.
Octabins	: In one way strong bulk octabins. Each one contains 400.000pcs.
Pallets	: In one way heat treated and fumigative pallets.
Protection	: All pallets are wrapped with stretch film for protection.
Enviroment	: All packaging materials are suitable for recycle.



Document title : Pry off crown profiles

•profile 916

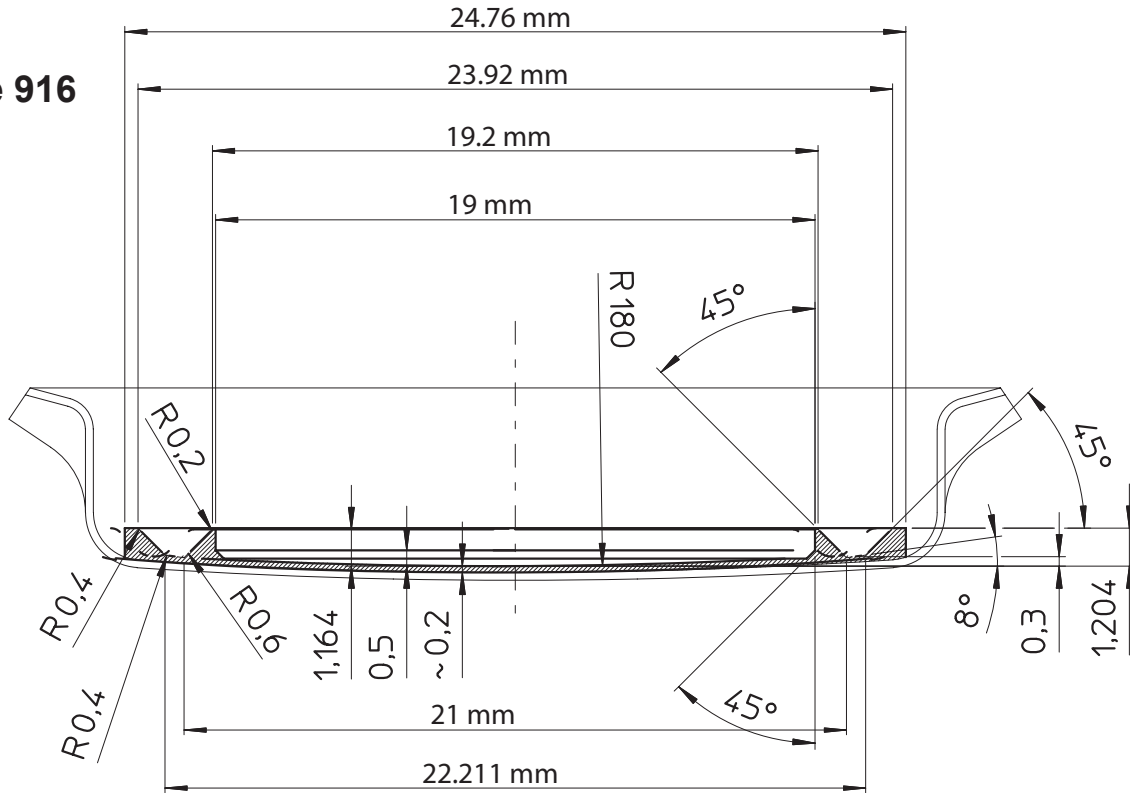

•profile 923

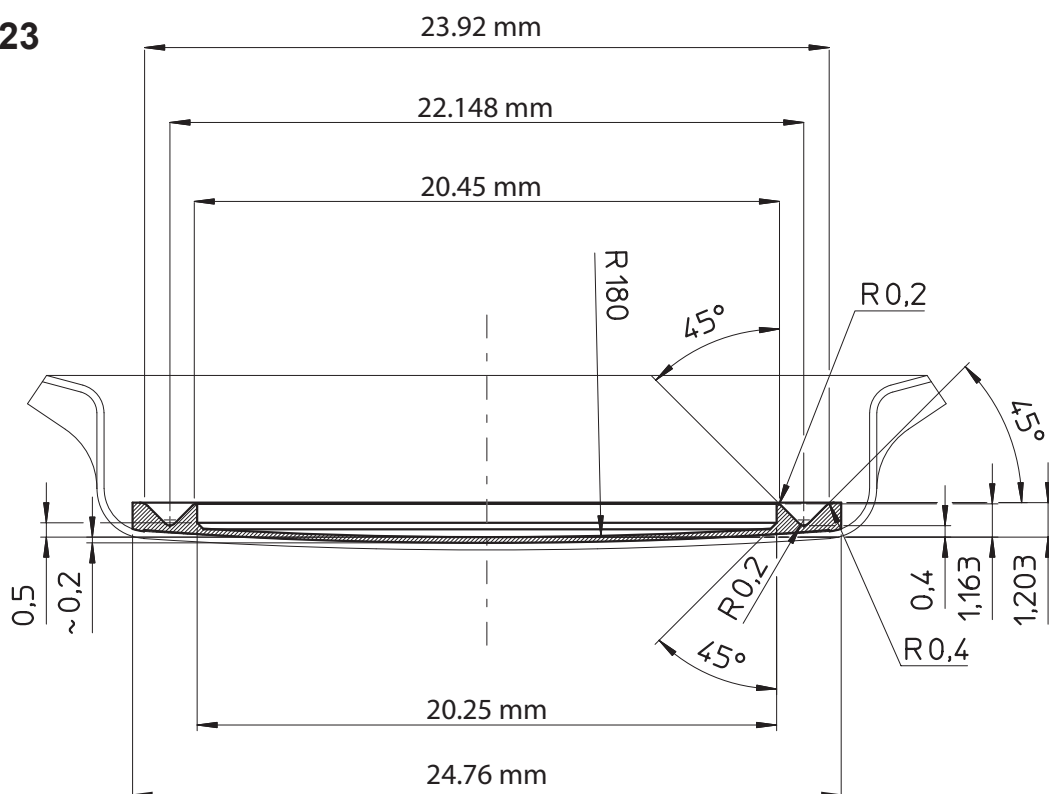



Document title : Twist off / Universal crown profiles

•profile 917

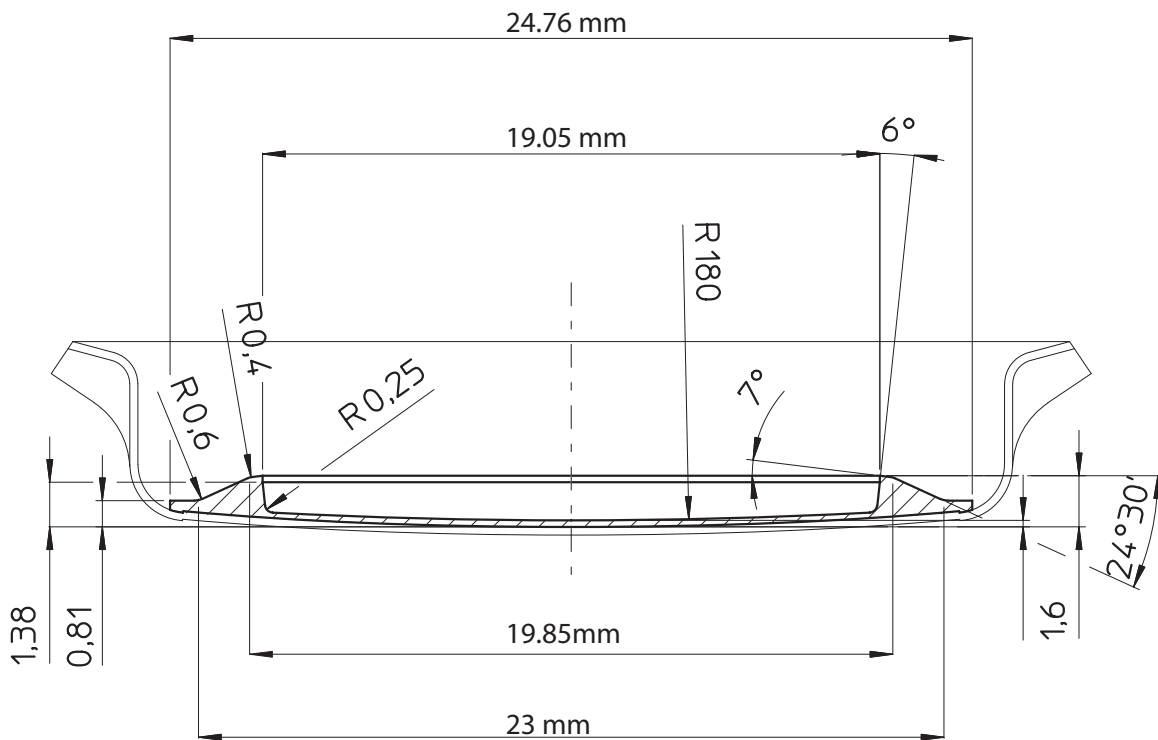

Remaks : Shown dimension before use

- Above specifications include acceptable tolerances for the crown cork application. Astir possesses all exclusive property, trademark and any other rights concerning all dimensional specifications. We do not undertake any liability regarding the observance of copyrights, trademarks or any other rights of third parties, even though has been supplied by ourselves.



Document title : Packaging Patterns

- Strong carton boxes
- With inner polyethylene bag
- Dimension 39x29x40 (LxWxH)
- Each contains 10.000 pcs / carton
- Net weight: 21 kgs
- Labelling with aii batch details
- Bar coding EAN 128

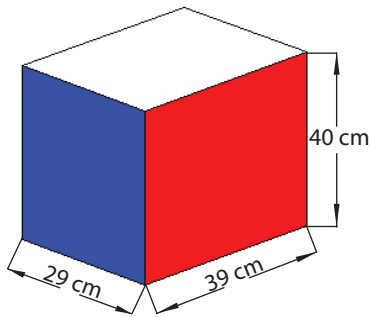

- Each row contains : 10 cartons / 100.000 pcs

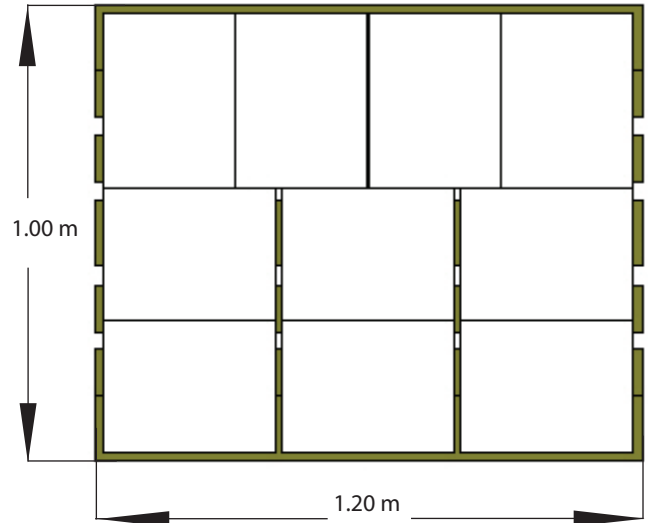

- 400.000 pcs Pallet Pattern
- Net weight pallet : 840 kgs

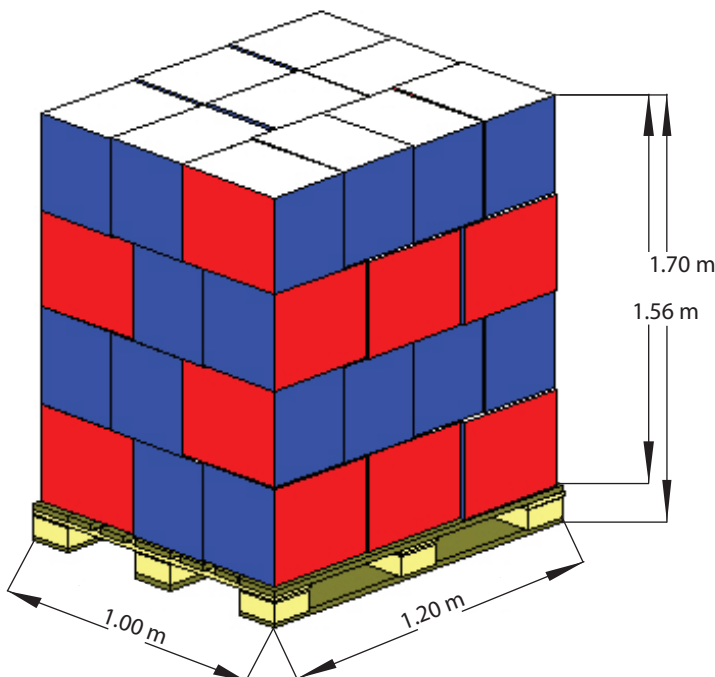

- 500.000 pcs Pallet Pattern
- Net weight pallet : 1050 kgs

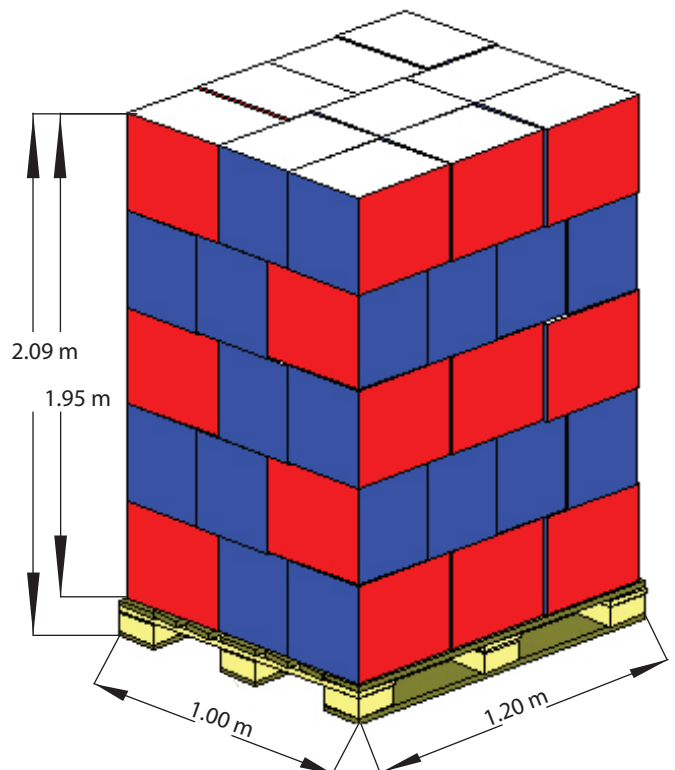



VITOGIANNIS BROS S.A.

CROWN CORKS MANUFACTURER

Position Draseza, Ind. Park of Avlona, PO Box16, PC 19011, Greece

Tel. + 30 22950 29371 Fax. + 30 22950 29373

www.vitogiannis.gr astir@vitogiannis.gr

Number document: ETP-101.2

Date edition: 25-06-2010



Document title : Loading / Dispatch Patterns

- i) 40" container, approx: 12,2m
contains 21 pallets of 400.000pcs = 8.400.000pcs
weight : 17.649 kgs

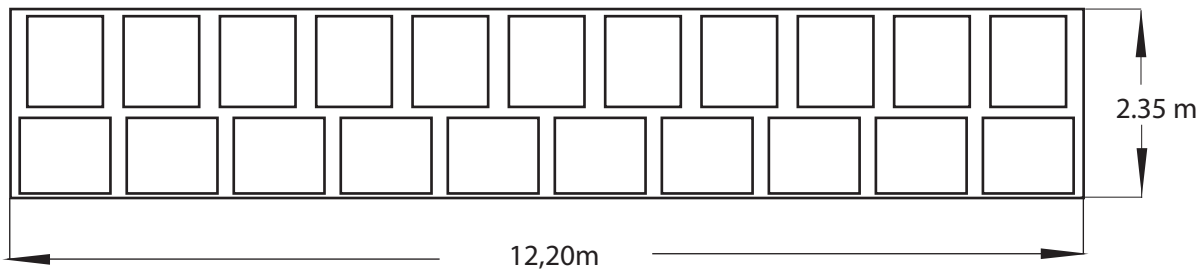

OR

- ii) 40" container, approx 12,2m
contains 18,5 pallets of 500.000pcs= 9.250.000pcs,
weight : 19.425 kgs

